



PROJECT		REF		REV	ITEM CODE	
LOCATION		DATE			PAGE	

SANITARY WARE SPECIFICATION SHEET

Item Descriptions	GROHE (Germany) "Tectron Skate" Infra-red electronic flushing control with manual actuation for WC flushing cistern	Illustration/ Drawing
Dimensions	L156 x W19 x H197 mm	
Model	37419SD0	
Material	Stainless Steel	
Manufacturer	GROHE Limited	
Source	Acme Sanitary Ware Co. Ltd Mr. Eric Wong/ Mr. Wilson Hung	
Contact Tel/Fax	(852) 2388-7171 / (852) 2710-8012	
E-mail	acme@acmesanitary.com.hk	
Website	www.acmesanitary.com.hk	
<ul style="list-style-type: none"> · with additional manual actuation · with infrared sensor for bi-directional communication for monitoring, configuration and servicing · with transformer 100-230 V AC, 50-60 Hz, 6 V DC · for single flush actuation · for flushing cistern GD 2 / Rapid SL 1.13 m only · servo motor · concealed installation · front plate 156 x 197 mm · hidden fixing screws · 7 pre-set programs · auto flush · cleaning mode · pre-flush on/off · additional functions and precise settings by remote control 36 407 · adjustable flush (3 - 9 l) by hand or remote · CE approved · for use with Rapid SLX please order shaft 66 791 000 (sold separately) 		

Note:

* All information of the above is for the reference only. No prior notice is made if any changes.



PROJECT		REF		REV	ITEM CODE	
LOCATION		DATE			PAGE	

SANITARY WARE SPECIFICATION SHEET

SPARE PARTS

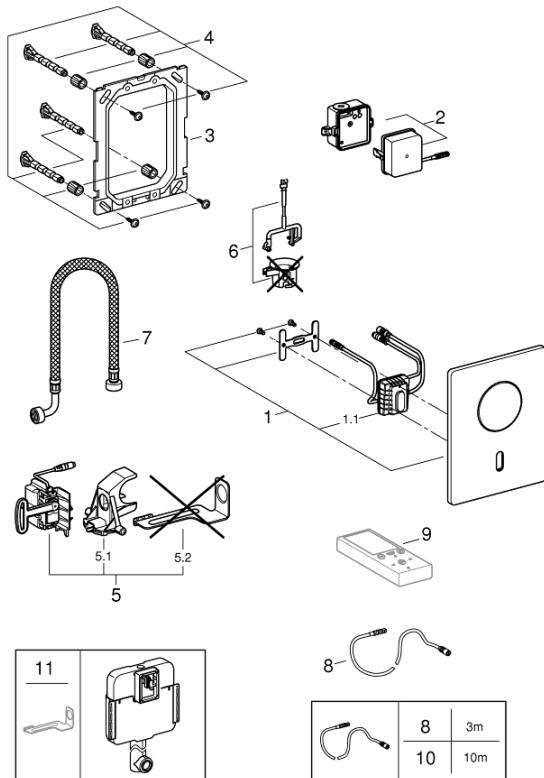

- 1: Top plate with electronic (Spare part-nr. 42440SD0)
 - 1.1: Electronic (Spare part-nr. 42439000)
 - 2: Switching power supply (Spare part-nr. 42470000)
 - 3: Frame (Spare part-nr. 42736000)
 - 4: Fixing set (Spare part-nr. 4215800M)
 - 5: Servo motor (Spare part-nr. 43281000)
 - 5.1: Support device (Spare part-nr. 42246000)
 - 5.2: Motor support device (Spare part-nr. 43617000)
 - 6: Mounting set (Spare part-nr. 43306000)
 - 7: Hose (Spare part-nr. 43307000)
 - 8: Extension cable (Spare part-nr. 36221000)
 - 9: Remote control (Spare part-nr. 36407001)*
 - 10: Extension cable (Spare part-nr. 36222000)*
 - 11: Motor support device (Spare part-nr. 43617000)*
- * Optional accessories

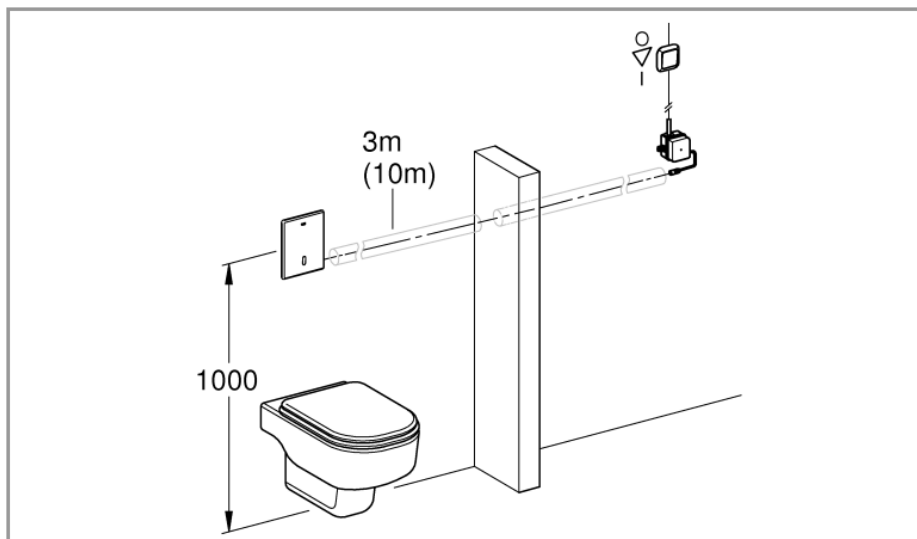

Note: